

## Lathe Steady for Spindle Turning

© Trevor Pope (tpope AT iafrica.com) – May 2016

Turning long, thin spindles on the lathe is not easy if you want to avoid excessive sanding. As a workpiece such as a chair leg is rotated against a cutting tool, the force required to remove material is resisted by the workpiece, causing it to deflect. Even the lightest cut will cause a noticeable deflection of the work workpiece. When the workpiece is long and thin, such as an elegant chair leg or spindle, it becomes correspondingly less stiff, and deflection becomes even more noticeable.

Wood is not a homogenous substance – it has grain and is not uniform in strength and density. This means that as the workpiece rotates, the cutting edge cuts through varying grain – radial or axial grain. Also the density of the wood may vary with growth rates of the tree in different seasons, over different years, and between sap wood and heart wood. As the workpiece rotates, the cutting edge generates variable cutting forces as the circumference moves past the edge, and the workpiece deflects accordingly.

All sorts of vibrations can be set up which complicate matters further. These vibrations cause wave patterns and ribs on the surface. Classical spindle turning requires one to use a sharp gouge and use a slicing cut, riding the bevel. Riding the bevel uses the workpiece to support the end of the gouge, to control the depth of cut. However, when ripples occur on the surface of the workpiece, these are just then replicated further. The picture shows ripples after roughing out, before the steady was used – small waves inside big waves!



In this case, the wood is White Stinkwood, *Celtis Africanus*, which is a ring-porous wood. It is quite hard and also exhibits a wide variation across the grain, so it is somewhat of a worst case.

To damp out the vibrations, the workpiece can be supported from behind with a hand, preferably inside a leather glove. This can be partially effective, but on longer spindles, this can be difficult. You can try different lathe speeds, different gouges, light cuts or scraping cuts. Holding the driving end in a chuck will impart some stiffness to that end, which will delay the onset or move the ripples further towards the tailstock end. You can try working from the ends inwards, to ride the bevel on the smooth wood, all with some degree of success, but as you get towards the centre, you may still find ripples. These can be quite considerable, several millimeters deep – too deep to sand out!

Time to consider a steady rest?

Those who have been turning for some time will have come across *“The Practical Wood Turner”* by Frank Pain, first published by Evans Brothers (publishers of *The Woodworker*) in 1957. It has been reprinted several times since, and is still available from Sterling Press.

Frank was the first professional woodturning demonstrator in the UK, and writes in an easy conversational style that probably reflected his narrative while he was demonstrating. Buddy Lawson met Frank many years ago, and will tell you about him if you ask. (See “Buddy Lawson meets Frank Pain” – unfortunately Buddy died earlier in 2019, aged 93, but you can still refer to the article.)

Frank tackled the issue of steady rests from a practical point of view in his book. I reproduced the section on steady rests from his book – see below. It is an entertaining read.

Following advice in the book, I made a steady rest for my lathe, which I found very effective in dealing with vibration on long spindles – some skill was still required to avoid ripples, but there was a remarkable improvement.

As Frank states, you will need to fit the design to your particular lathe, so I haven't given dimensions. I made mine from 50 x 75 SA pine and glued two pieces together. The lower piece fits between the bed bars of the lathe and a wedge from below holds it in place. A mortise was cut to house the follower and wedge in the upper piece. The follower pivots on a 6mm bolt held in place with a wing nut. The follower and wedge were made from some unidentified hardwood from the scrap box.



As you can see there is a significant improvement in the portion closer to the tail stock.

The follower is self adjusting due to the action of the wedge, simplifying use. You can see a light brown ring caused by friction of the follower on the workpiece. It is superficial and is easily removed with a light sanding. Candle wax applied to the contact area of the follower will prevent this.



The extract from the book follows on the next pages:

## Extract from “*The Practical Wood Turner*” by Frank Pain,

First published by Evans Brothers (the publishers of *The Woodworker*) in 1957. (Page 69 - ).

**Steady.** But let us now study the steady which was wanted chiefly for back legs and armchair legs. One is shown in Fig. 5 and is in the High Wycombe museum. These steadies were very crudely made. Wood-turners are notoriously bad at making things. In fact, if no wood-turning was needed, they would have to go plank-stacking in the timber yard. A few lathe manufacturers do make steadies, and although they are ideal for metal, they are of little use for wood. A steady for metal has to retain the work solidly against the thrust of the tool, and metal does not bend one way more than the other as wood does. I’ve yet to see metal burn as wood can.

So for wood we require a gentle thrust to counteract its tendency to bend more easily one way than the other (this is often the start of chatter in wood turning). We want a simple means of relieving this thrust when the wood starts burning; and it must have enough clearance so that a square can revolve before the wood is turned round. It must not be fussy as to size, for when we reduce the wood opposite the steady, it must adjust itself. Then, as only a few jobs require a steady, it must be easily removed from the lathe.

The wood-turner needing a steady would ask the timber-yard foreman for a chunk of throw-out wood. This he would ponder over, and at a suitable moment ask the band Sawyer to saw out something as in Fig. 6. There always seemed to be a box of old bolts, and one was fitted at (A) and another (probably ½ in.) with a wing nut at (B). A chairmaker was enlisted to screw a block of wood on the back, and it was tried several times in the lathe to see whether the wood could still revolve with it in place, and whether it would come out with the rest still in. The slip with a notch in it was pivoted at (B), and the width of wedge tried by experiment.

In the end, with the co-operation of the whole factory except the polishing shop, the job was done, a fine museum piece of work, which gladdened the heart, for it worked (that was the only reason it was made). It would help us if manufacturers would give us a start and provide the main part to fit on to the lathe bed, which is invariably round, and less handy than the two oblong sections of wood to fit in to.

**Why the steady works.** Let us see why it is so good. Fig. 6 shows a wedge against the underside of the lathe bed, pressing against the bolt, so forming a simple way of holding the steady firmly, yet easily removed by a biff. The wedge can be easily removed, and is to hand at the back of the steady when needed. The wood slip fits the work, and needs no special fitting. Its crudeness in no way hinders its use. If the wood becomes hot, a rub with some candle-grease will cure it. Should the work require more thrust, it can be given by nailing lead onto the wedge; or a rubber band can be passed over the top of the wedge and down beneath.

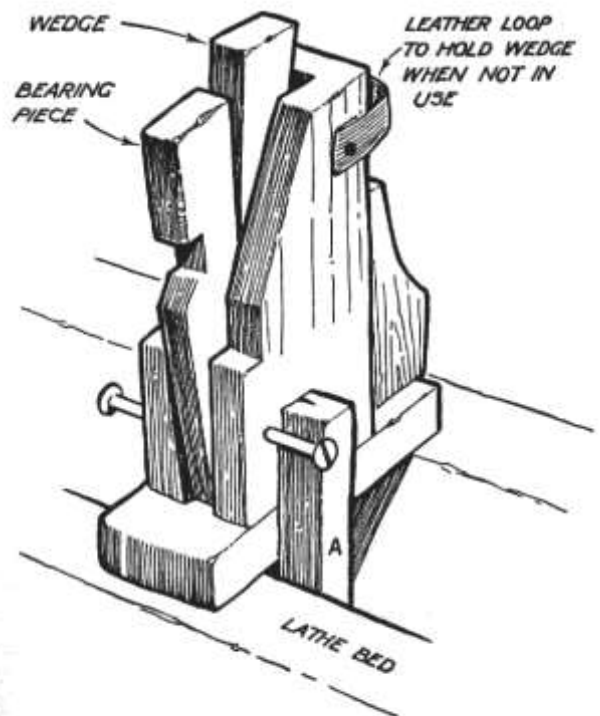

FIG. 5. BACK STEADY USED ON AN OLD LATHE. This apparently crude device is most effective in use. It is sketched from an old lathe in the Museum at High Wycombe, Bucks.

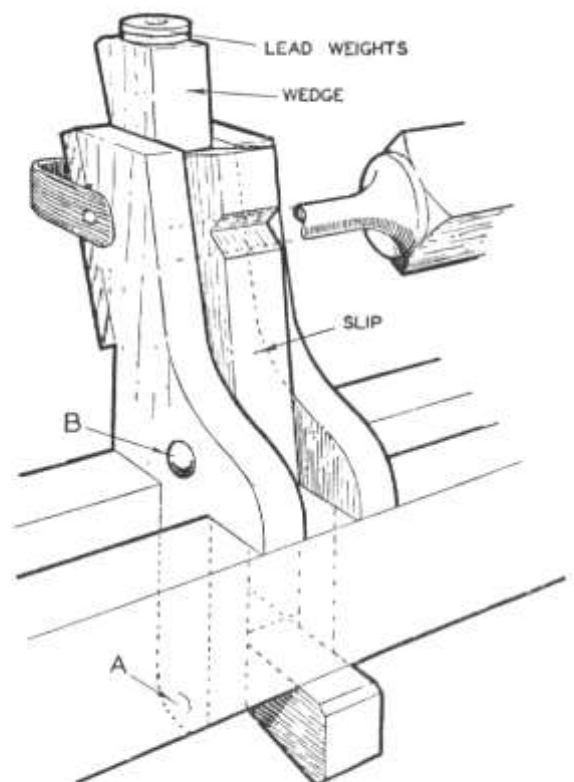

FIG. 6. SIMPLE YET EFFECTIVE STEADY FOR WOOD. The great advantage of this is that it maintains a constant light pressure. At the same time it is positive in that it resists thrust. Furthermore it automatically takes up to the reduced size of the wood when the latter is turned right opposite it.

One man I know has a screw which grips the wedge. He pushes the wedge down and tightens the screw which holds it there. A wing nut exerts enough pressure to prevent the slip from rising or falling, but allows it to swivel by action of the wedge. Some use a wood screw, but the principle is all you need worry about. If you draw a square at centre height at your lathe bed, you can work one out for your lathe. The wedge can be quite wide, as when it is withdrawn the slip goes further back out of the way. If you wish to do long stuff it is an ideal steady, and well worth making.

**Alternative steady.** If your lathe has twin beds you can make a simpler one which helps to steady the work, but is not as good. Still it has its uses as it can be quickly slipped into the bed where it is needed. Fig. 7 shows its principle. Part (A) slides down and so forces the slip against the work, but it does not prevent the work from moving up and down. Perhaps you want a simpler steady. Well a wedge inserted between the rest and work helps to do some jobs, but it burns easily as it has only a line contact.

**Preliminary rounding.** These steadies must have the work round, and back legs can be tiresome to turn round. You lightly put your hand around the revolving back leg, and, with a  $\frac{3}{8}$  in gouge, turn the part where the steady is to come. For an extremely difficult job you rasp it round first. The hand is around the work, not so much as a steady, but to catch the job if it flies out. Remember that we are thinking of long, springy items or they would not require a steady. If you find that it wears though to the bone, or if you can smell burning pork, try another way. Still, to put your hand around the work is helpful and safe.

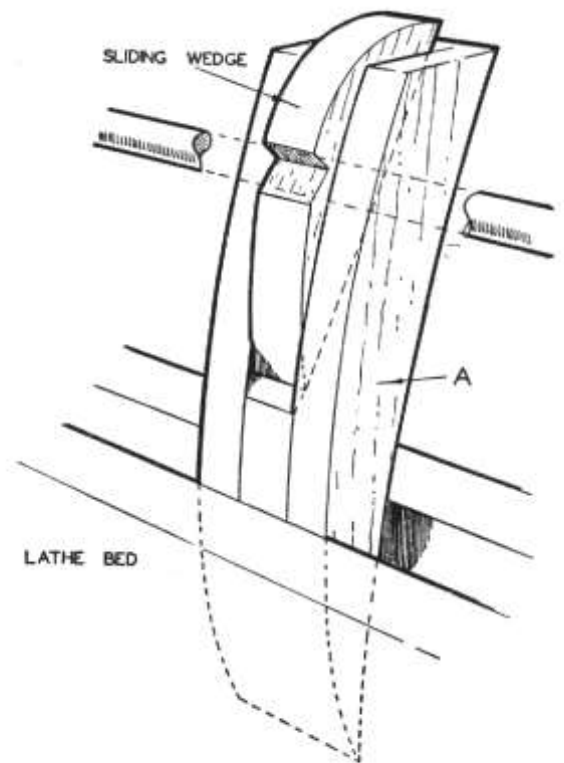

FIG. 7. SIMPLE ALTERNATIVE STEADY. Although not so effective as the steady in Fig. 6, this has its uses for some jobs.



FIG. 8. SIMPLE WOOD STEADY MADE FOR MYFORD LATHE. The idea could be adapted to suit any make of lathe. (A) is the wedge which tends to drop down by gravity and keep the slip (B) up to the work. The slip is pivoted at C).